

PowerWise Hardware Diagram

inGate - PowerScout 12 / PowerScout 48 Wiring 1.0

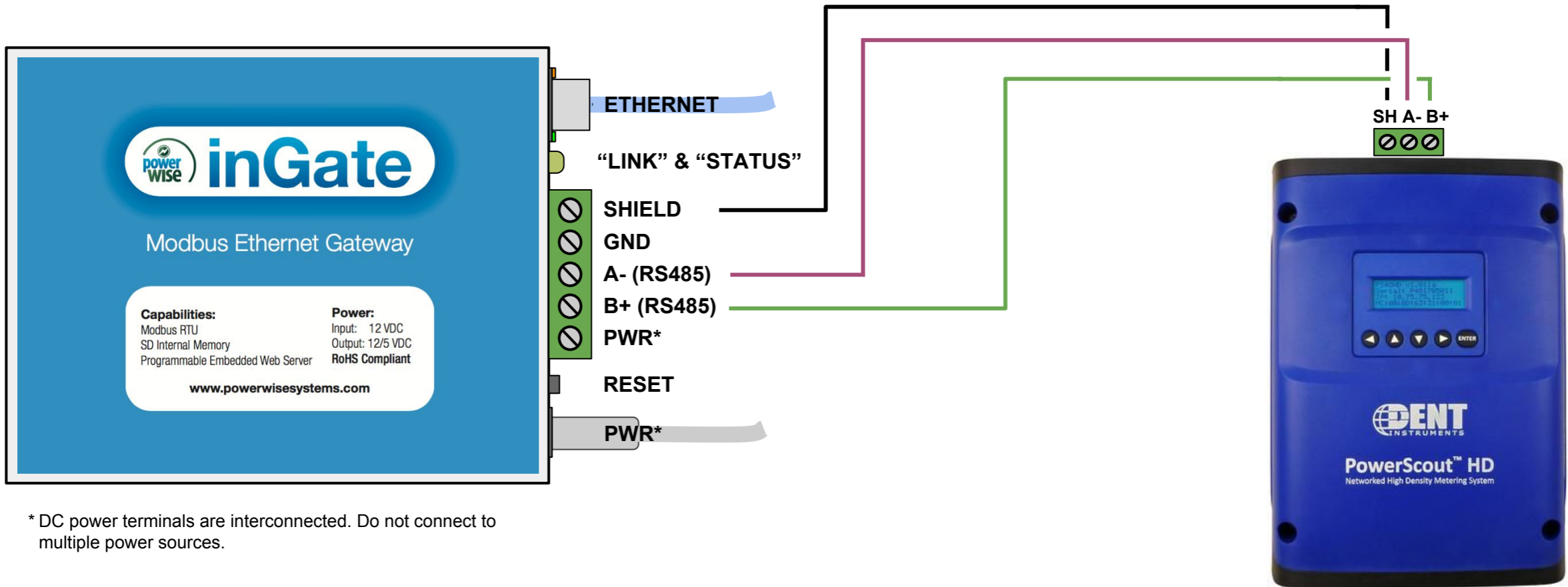

* DC power terminals are interconnected. Do not connect to multiple power sources.

Note - wire using CAT 5 or better