

# POWERWISE SYSTEMS HARDWARE DIAGRAM

## SiteSage V5 Gateway, sPod, Sensors, Flow Meter 4.0

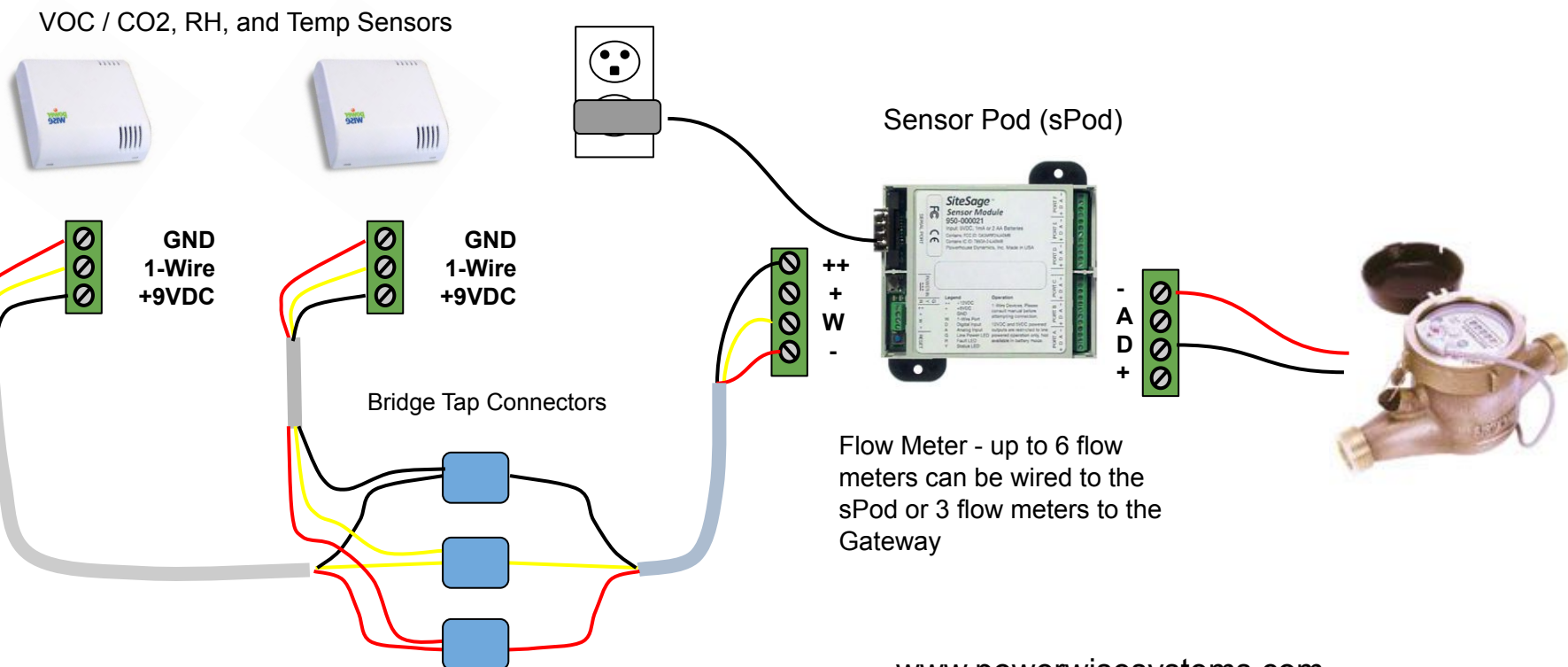

PowerWise  
124 Main Street  
Bucksport, ME 04416

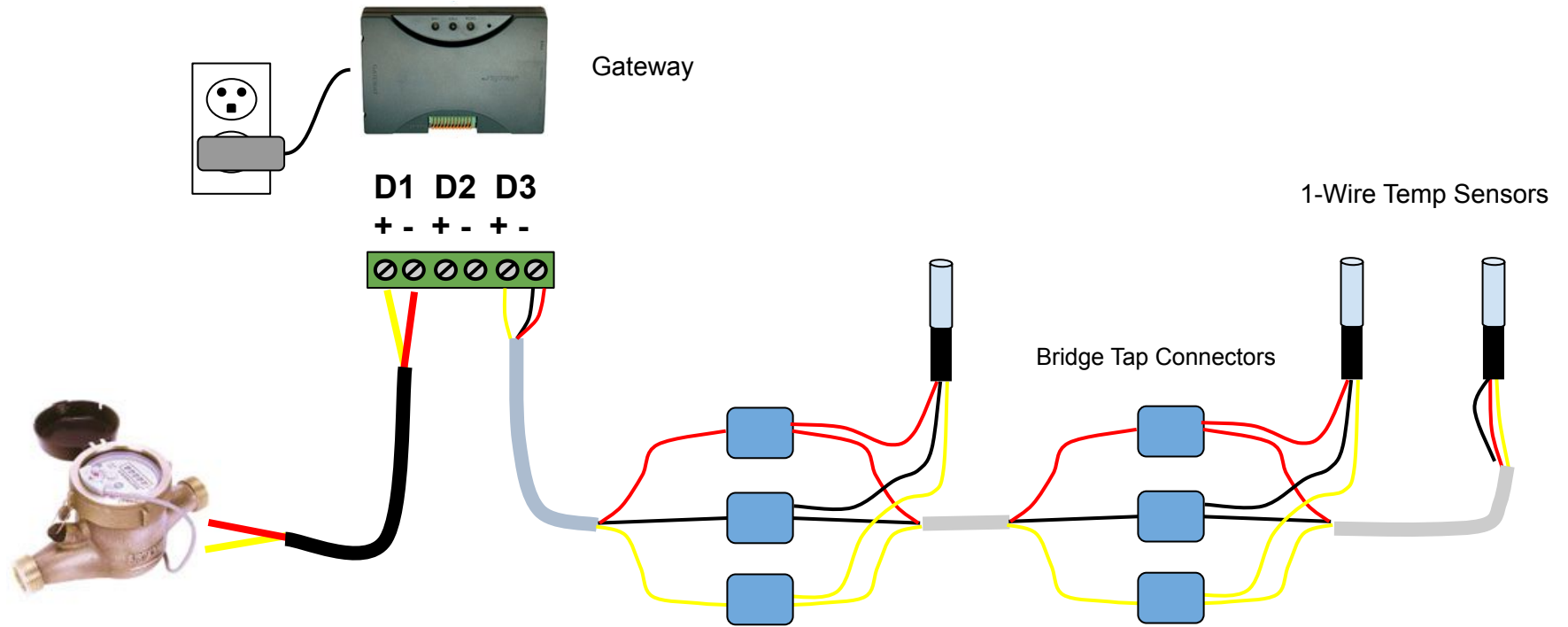

### NOTES:

- I. Gateway must be within 30 feet of the SiteSage Energy Monitor (not pictured), WiTemp+, and the sPod.
- II. SiteSage Gateway can connect via Ethernet or Wi-Fi. Gateway includes 5 VDC power supply. The device can also be powered over ethernet. The three gateway ports can be configured for pulse or 1-Wire in the app.
- III. PowerWise recommends using CAT5 or better with one twisted pair for the 1-Wire signal and ground. Do not run 1-Wire next to high-voltage wires. Sensor wiring trunks should be 100 feet or less. The trunk wire should not be spliced by cutting. Splices to the trunk should be 5 feet or more apart.
- IV. Maximum number of sensors that require power is 2 per Sensor Pod. Temp sensors do not require power.

WiTemp+ wireless temp sensor supports one 1-Wire temp sensor or one pulse meter



Data  
Common  
1-Wire